

RT 125°C, Standard 耐高温品

- 125°C, 2000 hours assured.
125°C, 2000 小时寿命品。
- Low Impedance, Anhydrous series.
高频低阻抗, 无水系产品
- Suitable for high reliability power supplies
适用于高可靠电源适配器



Specifications 特性表

Items 项目	Characteristics 主要特性																											
Rated Voltage Range 额定工作电压范围	6.3 ~ 100V _{dc}																											
Category Temperature Range 使用温度范围	-55 ~ +125°C																											
Capacitance Tolerance 静电容量允许偏差	±20% (M), at 20°C, 120Hz																											
Leakage Current 漏电流, 20°C环境下施加工作电压 2 分钟后. (at 20°C, After 2 minutes)	I ≤ 0.01CV or 3µA, whichever is greater 漏电流 ≤ 0.01CV or 3µA, 取较大值 Where, I : Max. leakage current (漏电流, µA), C : Nominal capacitance (静电容量, µF), V : Rated voltage (额定电压 V)																											
Dissipation Factor (Tanδ, at 20°C, 120Hz) 损耗角正切值 (测试条件为 20°C, 120Hz)	<table border="1"> <tr> <td>Rated voltage (V) 额定工作电压</td> <td>6.3</td> <td>10</td> <td>16</td> <td>25</td> <td>35</td> <td>50</td> <td>63</td> <td>100</td> </tr> <tr> <td>Tanδ (Max.) 最大损耗角正切</td> <td>0.22</td> <td>0.20</td> <td>0.16</td> <td>0.14</td> <td>0.12</td> <td>0.10</td> <td>0.10</td> <td>0.10</td> </tr> </table> <p>When nominal capacitance exceeds 1,000µF, add 0.02 to the value above for each 1,000µF increase. 静电容量大于 1000µF, 每增加 1000µF, 损耗角正切增加 0.02</p>	Rated voltage (V) 额定工作电压	6.3	10	16	25	35	50	63	100	Tanδ (Max.) 最大损耗角正切	0.22	0.20	0.16	0.14	0.12	0.10	0.10	0.10									
Rated voltage (V) 额定工作电压	6.3	10	16	25	35	50	63	100																				
Tanδ (Max.) 最大损耗角正切	0.22	0.20	0.16	0.14	0.12	0.10	0.10	0.10																				
Low Temperature Characteristics (Max. Impedance Ratio, 120Hz) 低温特性最大阻抗比	<table border="1"> <tr> <td>Rated voltage (V) 额定工作电压</td> <td>6.3</td> <td>10</td> <td>16</td> <td>25</td> <td>35</td> <td>50</td> <td>63</td> <td>100</td> </tr> <tr> <td>Z(-25°C)/Z(20°C)</td> <td>2</td> <td>2</td> <td>2</td> <td>2</td> <td>2</td> <td>2</td> <td>2</td> <td>2</td> </tr> <tr> <td>Z(-40°C)/Z(20°C)</td> <td>5</td> <td>5</td> <td>4</td> <td>3</td> <td>3</td> <td>3</td> <td>3</td> <td>3</td> </tr> </table>	Rated voltage (V) 额定工作电压	6.3	10	16	25	35	50	63	100	Z(-25°C)/Z(20°C)	2	2	2	2	2	2	2	2	Z(-40°C)/Z(20°C)	5	5	4	3	3	3	3	3
Rated voltage (V) 额定工作电压	6.3	10	16	25	35	50	63	100																				
Z(-25°C)/Z(20°C)	2	2	2	2	2	2	2	2																				
Z(-40°C)/Z(20°C)	5	5	4	3	3	3	3	3																				
Endurance 耐久性	<p>The following specification shall be satisfied when the capacitors are restored to 20°C after subjected to DC voltage with the ripple current is applied for the specified period of time at 125°C. 在 125°C 环境中, 不超过额定电压的范围下叠加额定纹波电流, 连续加载规定时间的额定电压后, 待温度恢复到 20°C 进行测量时, 应满足以下要求。</p> <table border="1"> <tr> <td>Test Time 测试时间</td> <td>2,000Hrs (Φ5~Φ6.3: 1000Hrs)</td> </tr> <tr> <td>Capacitance Change 静电容量变化率</td> <td>Within ±20% initial value 初始值的±20%以内</td> </tr> <tr> <td>Dissipation Factor 损耗角正切</td> <td>≤200% of specified value 不大于规范值的 200%</td> </tr> <tr> <td>Leakage Current 漏电流</td> <td>≤The initial specified value 不大于规范值</td> </tr> </table>	Test Time 测试时间	2,000Hrs (Φ5~Φ6.3: 1000Hrs)	Capacitance Change 静电容量变化率	Within ±20% initial value 初始值的±20%以内	Dissipation Factor 损耗角正切	≤200% of specified value 不大于规范值的 200%	Leakage Current 漏电流	≤The initial specified value 不大于规范值																			
Test Time 测试时间	2,000Hrs (Φ5~Φ6.3: 1000Hrs)																											
Capacitance Change 静电容量变化率	Within ±20% initial value 初始值的±20%以内																											
Dissipation Factor 损耗角正切	≤200% of specified value 不大于规范值的 200%																											
Leakage Current 漏电流	≤The initial specified value 不大于规范值																											
Shelf Life 高温贮存	<p>The above specifications shall be satisfied when the capacitors are restored to 20°C after exposing them for 1,000 hours at 105°C without voltage applied. Before the measurement, the capacitor shall be preconditioned by applying voltage according to Item 4.1 of IEC 60384-4. 在 105°C 环境中, 无负荷放置 1,000 小时后待温度恢复到 20°C, 进行试验前处理(IEC 60384-4 4.1 项)后进行测量时, 应满足以下要求。</p> <table border="1"> <tr> <td>Capacitance Change 静电容量变化率</td> <td>Within ±20% initial value 初始值的±20%以内</td> </tr> <tr> <td>Dissipation Factor 损耗角正切值</td> <td>≤200% of specified value 不大于规范值的 200%</td> </tr> <tr> <td>Leakage Current 漏电流</td> <td>≤The initial specified value 不大于规范值</td> </tr> </table>	Capacitance Change 静电容量变化率	Within ±20% initial value 初始值的±20%以内	Dissipation Factor 损耗角正切值	≤200% of specified value 不大于规范值的 200%	Leakage Current 漏电流	≤The initial specified value 不大于规范值																					
Capacitance Change 静电容量变化率	Within ±20% initial value 初始值的±20%以内																											
Dissipation Factor 损耗角正切值	≤200% of specified value 不大于规范值的 200%																											
Leakage Current 漏电流	≤The initial specified value 不大于规范值																											

Drawing(Unit: mm) 外形图

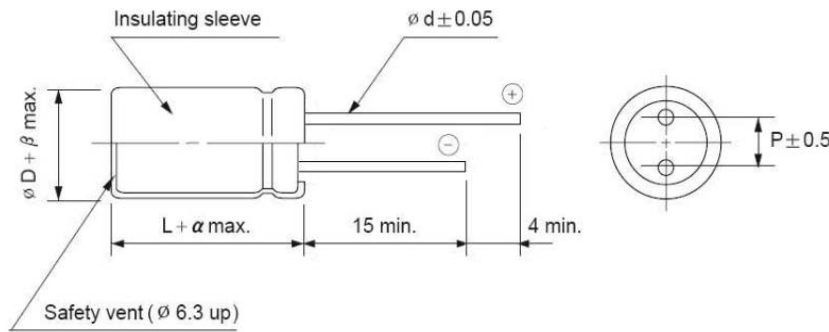

ΦD	5	6.3	8	10	13	16	18
P	2.0	2.5	3.5	5.0	5.0	7.5	7.5
Φd	0.5		0.6		0.8		
α	1.0			1.5			
β	0.5						

Rated ripple current multipliers(Unit: mm) 额定纹波修正系数

Frequency 频率 (Hz)	60Hz	120Hz	300Hz	1KHz	10KHz	100KHz	
Coefficient 系数	Under 10µF	0.35	0.42	0.50	0.60	0.80	1.00
	10 < C ≤ 39	0.45	0.55	0.62	0.75	0.90	1.00
	47 < C ≤ 390	0.60	0.70	0.76	0.85	0.95	1.00
	470 < C ≤ 1800	0.65	0.75	0.82	0.90	0.98	1.00
	2200 up above	0.75	0.80	0.86	0.95	1.00	1.00

The endurance of capacitors is reduced with internal heating produced by ripple current at the rate of halving the lifetime with every 5°C rise.
铝电解电容器由于在纹波电流叠加时自我发热、温度上升而老化, 每升温 5°C 寿命减少一半。

When long life performance is required in actual use, the rms ripple current has to be reduced.
要想保持长寿命请在使用过程中降低纹波电流。

RT Series

Standard ratings 标准品一览表

WV μF	6.3			10			16			25		
	ΦD x L	Impedance	R.C.	ΦD x L	Impedance	R.C.	ΦD x L	Impedance	R.C.	ΦD x L	Impedance	R.C.
4.7										5x11	0.6	180
10										5x11	0.6	180
22										5x11	0.6	180
33										5x11	0.6	180
39										5x11	0.6	180
47										5x11	0.6	180
56							5x11	0.6	180	5x11	0.5	200
82							5x11	0.5	200	6.3x11	0.25	290
100	5x11	0.6	180	5x11	0.6	180	6.3x11	0.25	290	6.3x11	0.25	290
120	5x11	0.5	200	5x11	0.5	200	6.3x11	0.25	290	6.3x15	0.23	430
150	6.3x11	0.25	290	6.3x11	0.25	290	6.3x11	0.25	290	8x11.5	0.117	555
180	6.3x11	0.25	290	6.3x11	0.25	290	6.3x15	0.23	430	8x11.5	0.117	555
220	6.3x11	0.25	290	6.3x11	0.25	290	8x11.5	0.117	555	8x11.5	0.117	555
330	6.3x11	0.25	290	8x11.5	0.117	555	8x11.5	0.117	555	10x12.5	0.09	755
470	8x11.5	0.117	555	8x11.5	0.117	555	10x12.5	0.09	755	10x16	0.068	1050
560	8x11.5	0.12	555	10x12.5	0.1	660	10x16	0.075	890	10x20	0.052	1220
680	10x12.5	0.09	755	10x12.5	0.09	755	10x16	0.068	1050	10x20	0.052	1220
820	10x12.5	0.09	755	10x16	0.082	830	10x20	0.052	1220	10x25	0.045	1440
1000	10x12.5	0.09	755	10x16	0.068	1050	10x20	0.052	1220	13x20	0.038	1655
1200	10x16	0.068	1050	10x20	0.052	1220	10x25	0.045	1440	13x20	0.034	1680
1500	10x20	0.052	1220	10x20	0.052	1220	13x20	0.038	1655	13x25	0.03	1945
1800	10x20	0.048	1220	10x25	0.045	1440	13x20	0.034	1680	13x30	0.025	2310
2200	13x20	0.038	1815	13x20	0.038	1655	13x25	0.03	1945	16x25	0.022	2555
2700	13x20	0.038	1815	13x25	0.03	1945	13x30	0.025	2310	16x25	0.022	2555
3300	13x20	0.038	1655	13x25	0.03	1945	16x25	0.022	2555	16x31.5	0.018	3010
3900	13x25	0.03	1945	16x25	0.022	2510	16x25	0.022	2555	18x31.5	0.016	3635
4700	16x25	0.022	2555	16x25	0.022	2555	18x25	0.02	2740	18x35.5	0.015	3680
5600	16x25	0.022	2510	16x25	0.022	2555	18x31.5	0.016	3635			
6800	16x25	0.022	2555	16x31.5	0.018	3010	18x35.5	0.015	3680	18x40	0.014	3800
8200	16x31.5	0.018	3010	18x31.5	0.016	3635	18x35.5	0.015	3680			
10000	16x31.5	0.016	3150	18x35.5	0.015	3680	18x40	0.014	3800			
12000	18x31.5	0.016	3635									

WV μF	35			50			63			100		
	ΦD x L	Impedance	R.C.	ΦD x L	Impedance	R.C.	ΦD x L	Impedance	R.C.	ΦD x L	Impedance	R.C.
0.47										5x11	43	20
1										5x11	20	30
2.2										5x11	9.8	44
3.3										5x11	6.6	58
4.7	5x11	0.6	180	5x11	2.3	90	5x11	4.7	68	5x11	4.6	74
10	5x11	0.6	180	5x11	1.4	120	5x11	2.1	110	6.3x11	1.8	130
22	5x11	0.60	180	5x11	1.2	170	6.3x11	0.71	250	8x11.5	0.68	230
47	6.3x11	0.25	290	6.3x11	0.43	300	8x11.5	0.342	405	10x16	0.37	420
100	8x11.5	0.117	555	8x11.5	0.234	485	10x12.5	0.256	535	13x20	0.180	580
220	10x12.5	0.090	755	10x16	0.119	850	10x20	0.147	885	16x25	0.100	890
330	10x16	0.068	1050	10x20	0.09	1030	13x20	0.085	1285	16x25	0.09	1080
470	10x20	0.052	1220	13x20	0.06	1500	13x25	0.07	1720	16x31.5	0.076	1310
1000	13x25	0.03	1945	16x25	0.034	2235	16x31.5	0.043	2670			
2200	16x31.5	0.018	3010	18x35.5	0.023	3100	18x40	0.028	3200			
3300	18x35.5	0.015	3680									
4700	18x40	0.014	3800									

Note1: Case size ΦD x L(mm), ripple current (mA, rms) at 105°C, 100KHz. 尺寸 ΦD x L(mm), 纹波电流於 105°C, 100KHz

Note2: Produce custom product too, which are not found in these tables. 客户定制品不在标准品一览表内

Note: All design and specifications are for reference only and is subject to change without prior notice. If any doubt about safety for your application, Please contact us immediately for technical assistance before purchase.

注: 以上所提供的设计及特性参数仅供参考, 任何修改不作预先通知, 如有使用上任何疑问, 请在采购前与我们联系, 以便提供技术上的协助.