

产品图纸:

HP 系列:0.35-60F

尺寸

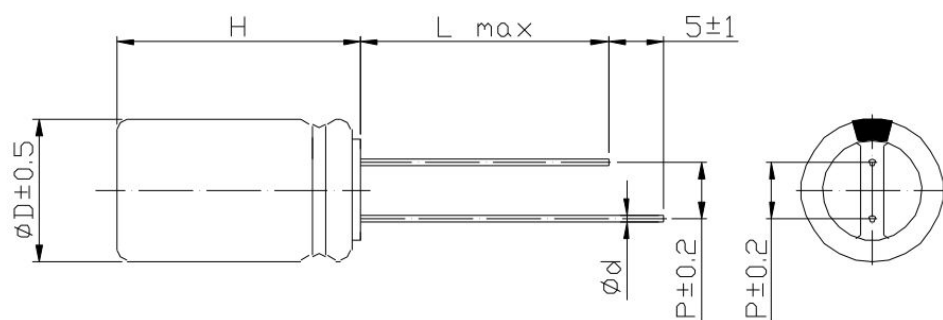

HP 系列:90-800F

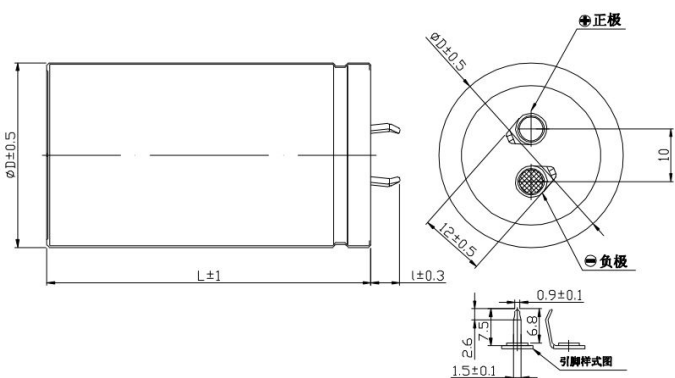

HP 系列: 350F

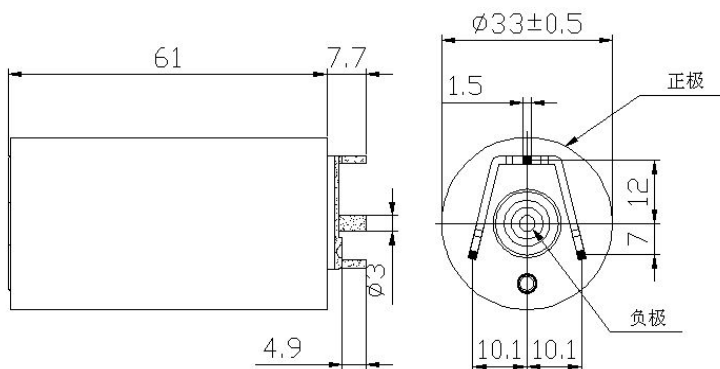

HP 系列: 3000F

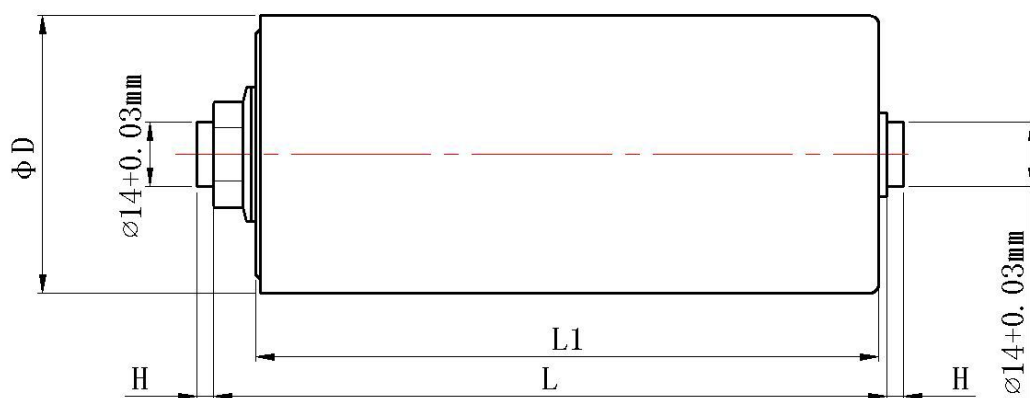

产品性能表

型号	容量 F	内阻 mΩ		额定 电流 A	最大 电流 A	24h 漏 电流 μA	最大 能量 mWh	能量 密度 Wh/kg	最大 功率 W	功率 密度 W/kg	产品 重量 g	产品尺寸 mm		
		直流	交流 1kHz									直径 D	长度 H	脚距 P
HP-2R7-J354UY LR	0.35	500	250	0.12	0.3	3.5	0.30	0.51	3.65	6075	0.6	5	12	2
HP-2R7-J704VY LR	0.7	600	300	0.2	0.55	7	0.61	0.41	3.04	2025	1.5	8	13	3.5
HP-2R7-J105VY LR	1	600	300	0.27	0.65	10	0.87	0.58	3.04	2025	1.5	8	13	3.5
HP-2R7-J205VY LR	2	260	130	0.5	1.2	20	1.74	0.87	7.01	3505	2	8	20	3.5
HP-2R7-J205VY LR	2	240	120	0.5	1.2	20	1.74	0.87	7.59	3797	2	10	20	5
HP-2R7-J335TY LR	3.3	500	250	0.9	2.1	33	2.86	1.79	3.65	2278	1.6	8	20	3.5
HP-2R7-J335VY LR	3.3	140	70	0.9	2.1	33	2.86	1.19	13.02	5424	2.4	10	20	5
HP-2R7-J475VY LR	4.7	120	60	1.1	2.6	47	4.08	1.32	15.19	4899	3.1	12.5	21	5
HP-2R7-J805UY LR	8	100	50	1.6	3.2	80	6.94	1.74	18.23	4556	4	12.5	21	5
HP-2R7-J106UY LR	10	160	80	2	4.5	100	8.68	1.97	11.39	2589	4.4	12.5	26	5
HP-2R7-J106UY LR	10	120	60	2	4.5	100	8.68	1.40	15.19	2450	6.2	12.5	34	5
HP-2R7-J126UY LR	12	70	35	2.5	5.4	120	10.42	1.60	26.04	4005	6.5	12.5	34	5
HP-2R7-J156UY LR	15	60	30	4	7.5	150	13.02	1.74	30.38	4050	7.5	16	26	7.5
HP-2R7-J206UY LR	20	46	23	5.2	11	200	17.36	1.58	39.62	3602	11	16	34	7.5
HP-2R7-J256UY LR	25	100	50	5.2	18	250	21.70	1.97	18.23	1657	11	16	34	7.5
HP-2R7-J306UY LR	30	40	20	6.5	18.8	300	26.04	2.96	45.56	5178	8.8	16	34	7.5
HP-2R7-J506UY LR	50	40	20	11.2	33.7	500	50.63	4.05	45.5	3645	12.5	18	42	7.5
HP-2R7-J606UY LR	60	40	20	13.0	36.8	600	60.75	4.67	45.5	3505	13	18	42	7.5
HP-2R7-J906UY LR	90	30	15	19.1	51.6	900	91.13	4.56	60.7	3038	20	22	46	10
HP-2R7-J107UY LR	100	30	15	20.7	54	1000	101.25	4.60	60.7	2761	22	22	46	10
HP-2R7-J127UY LR	120	30	15	23.8	57.8	1200	121.50	4.50	60.7	2250	27	25	54	10
HP-2R7-J157UY LR	150	30	15	27.9	62.3	1500	151.88	4.75	60.7	1898	32	25	54	10
HP-2R7-J207UY LR	200	20	10	38.5	90	2000	202.50	4.40	91.1	1981	46	35	62	10
HP-2R7-J227UY LR	220	20	10	41.2	92.8	2200	222.75	5.18	91.1	2119	43	30	50	10
HP-2R7-J307UY LR	300	20	10	50.6	101.	3000	303.75	5.06	91.1	1519	60	35	62	10
HP-2R7-J367UY LR	360	4	2	84.9	282.	3600	364.50	5.21	455.	6509	70	35	62	10
HP-2R7-J407UY LR	400	20	10	60	108	4000	405.00	5.79	91.1	1302	70	35	62	10
HP-2R7-J357UC LR	350	3	1.6	60	110	3500	354.38	5.06	607.	8679	70	35	62	/
HP-2R7-J308UL LR	3000	0.29	0.25	720	2530	3000	3037.5	5.33	6284	11025	570	60	140	/
HP-2R7-J354UY LL	0.35	1200	600	0.08	0.33	2.8	0.30	0.51	1.52	2531	0.6	5	12	2
HP-2R7-J504VY LL	0.5	1200	600	0.14	0.48	4	0.43	0.72	1.52	2531	0.6	6.3	13	2.5
HP-2R7-J704VY LL	0.7	1200	600	0.2	0.55	5.6	0.61	0.41	1.52	1013	1.5	8	13	3.5
HP-2R7-J105VY LL	1	1200	600	0.27	0.65	8	0.87	0.58	1.52	1013	1.5	8	13	3.5

HP-2R7-J205VY LL	2	500	250	0.5	1.2	16	1.74	0.87	3.65	1823	2	8	20	3.5
HP-2R7-J335TY LL	3.3	500	250	0.9	2.1	26.4	2.86	1.59	3.65	2025	1.8	8	20	3.5
HP-2R7-J335TY LL	3.3	500	250	0.9	2.1	26.4	2.86	1.59	3.65	2025	1.8	8	24	3.5
HP-2R7-J335VY LL	3.3	400	200	0.9	2.1	26.4	2.86	1.59	4.56	2531	1.8	10	20	5
HP-2R7-J475VY LL	4.7	240	120	1.1	2.6	37.6	4.08	1.32	7.59	2450	3.1	12.5	21	5
HP-2R7-J805UY LL	8	200	100	1.6	3.2	64	6.94	1.74	9.11	2278	4	12.5	21	5

产品性能曲线:

HP LR 产品:

HP LL 产品:

